

Cabling Performance vs. Component Conformance

Within international standards for generic cabling, such as ISO/IEC 11801, we have specifications for the transmission performance of balanced cabling channels and links defined as Classes A to E, EA, F and FA. Conformance to the standard requires that the required channel Class is achieved. The same system is adopted in Europe and in the UK is published within the BS EN 50173 series of standards (although the BS EN 50173-1 amendment containing Classes EA and FA is not published yet).

In the equivalent US standard, the ANSI/TIA/EIA-568-C series, the transmission performance of balanced cabling channels and links is defined in terms of Category - with Category 5e, 6 and augmented Category 6 being approximately the same as Class D, Class E and Class EA of the ISO/IEC standards.

In all the standards the component requirements, covering cables, connecting hardware and cords, are specified in terms of Category.

One way of achieving the desired channel performance is to use components of the correct Category 6 in the correct configuration (sometimes known as a "reference implementation"). Using such reference implementations Category 5 components may create Class D channels (in the ISO/IEC and BS EN world) or Category 5 channel (in ANSI/TIA/EIA world).

However, two important phrases are used in the preceding paragraph and are marked in italic text. The first is the use of the term "one way". There are in fact three separate routes to conformance with the desired ISO/IEC and BS EN channel performance and only one requires the use of components of a defined Category. The second important issue is the use of the word "may". This is because the use of components of a given Category in a reference implementation does not guarantee the required channel performance. Figure 1 shows the relevant text in the relevant BS EN 50173-x standards (it is essentially the same in ISO/IEC 11801). The key terms are in the third bullet and are "based upon a statistical approach to performance modelling" which undermines the traditional, and arguably perfectly reasonable, assumption that if cables, connecting hardware and cords conform to a specific Category then any resulting cabling will also meet the requirements for links and channels respectively. To understand why this text is included in the standards one has to remember that cabling and component performance requirements are in a continual state of development. In the 1995 edition of ISO/IEC 11801 (and BS EN 50173) we only had to consider Class D:1995 channels created using Category 5:1995 components. In 2002 the Class D channels and Category 5 components were updated - harmonising them with the then new Category 5e requirements specified in the North American Standards. In addition, we introduced channel Classes E and

d) the performance of channels shall conform to the requirements of Clause 5. This shall be achieved by one of the following"

- a channel design and implementation ensuring that the prescribed channel performance Class of Clause 5 is met;
- attachment of appropriate components to a link design meeting the prescribed performance Class of Annex A. Channel performance shall be assured where a channel is created by adding more than one cord to either end of a link meeting the requirements of Annex A;
- using the reference implementations of Clause 6 and compatible cabling components confirming to the requirements of Clauses 7, 8 and 9, based upon a statistical approach of performance modelling.

Figure 1 - Extract from the conformance clause of BS EN 50173-2

Class F along with Category 6 and 7 components. It was this that forced the universal amendment of the conformance clause exemplified in Figure 1 after the detailed performance modelling use to determine the performance of the components showed that channel performance could not be guaranteed in all circumstances - for all Classes.

The situation has not only not improved but has got worse with the current introduction of Category 6A and 7A components that may be used to create Class EA and FA channel respectively. Now the modelling indicates that statistical risk has increased and, even worse, that certain configurations of Class FA cabling requires the use of components of performance significantly in excess of Category 7A.

So, in the face of this rather unwelcome news, how should customers specify their needs?

Quite clearly, simply specifying components of a given Category is not the way to proceed unless the specifier has a

full understanding of the situations under which the statistical risk to either link to channel performance applies. In fact since two of three routes to conformance do not require the use of specific components (and the third requires technical knowledge or advice) then a simple and dogmatic reliance on component Categorisation would seem to represent a demonstrably poor solution - particularly as the required channel performance increases.

The problems with relying on component performance alone begins with the structure of a channel. As shown in Figure 2, a channel is created by adding some cords to a fixed installation. The cords are added at the telecommunications outlet (TO),

connecting the fixed cabling to the equipment in the work area (work area cord) and at the panels in the distributor, either as direct interconnection to equipment (using an equipment cord) or an indirect connection via cross-connect (using both an equipment cord and a patch cord). If a consolidation point (CP) is used then two cords are needed to connect the CP to the work area equipment.

It is not only the presence of cords attached to the fixed cabling that creates the challenge to channel performance but their number, length and performance. It will be noted that the second route to conformance described in Figure 1 states that “channel performance shall be assured when adding more than one cord to either end of a conformant link”. This means that just because the fixed installation has been tested and shown to be conformant (e.g. a Class E link) there is no guarantee that Class E channels are automatically created by adding more than one cord of Category 6 at one or both ends. Instead, the standards require the attachment of “appropriate” components. This means “appropriate” to the design of the link and the resulting channel.

A requirement of BS EN 50173-2 (applicable to all premises adopting office cabling structures) is to design horizontal cabling to provide a minimum of Class D channel performance - allowing the customer the option to specify a higher Class if required. The key thing is to have a design that ensures that the required channel Class can be created. This means that the supplier should advise the client of the conditions under which the desired Class will be achieved taking into account the configuration of the cabling and the environment to which the cabling is subjected.

For example, for a given length of equipment cord at the distributor, which lengths of patch cords should be avoided if resonance-related failures are to be prevented. Similarly, what combinations of CP cord and work area cord lengths must be avoided for the same reasons. Furthermore, are there recommended restrictions of minimum fixed cabling lengths to prevent link test failures where CPs are used - and, finally, what is the impact on fixed cabling lengths of using long cords or where the cabling experiences elevated temperatures - such as those generated by Power over Ethernet.

The answers to these types of question are significantly more important than whether a specific component meets a particular Category. Moreover, it is impossible to determine from the results obtained from a link or channel test:

- Whether or not the components within the cabling met a specific Category
- Whether that Category of performance was achieved by those components in the installed condition.

Therefore, whilst it may be desirable to specify components of a given Category, it has to be considered to be a secondary consideration.

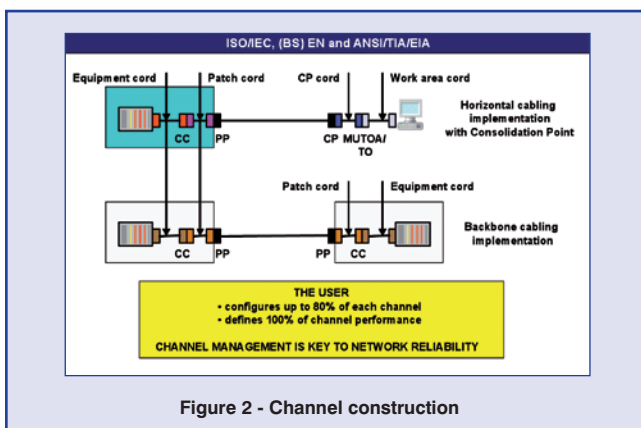

Figure 2 - Channel construction

Bibliography

- | | |
|--------------------|--|
| ANSI TIA/EIA-568-C | Generic Customer-Owned Telecommunications Networks series |
| BS EN 50173-x:2007 | Information technology - Generic cabling series |
| BS EN 50173-2:2007 | Information technology - Generic cabling - Office premises |
| ISO/IEC 11801 | Information technology - Generic cabling for customer premises |

This White Paper has been produced by Mike Gilmore, e-Ready Building Limited, on behalf of Mayflex.

If Mayflex wish to denote the author in association with the text of the White Paper then any changes instituted by Mayflex shall be agreed with e-Ready Building Limited. Alternatively, if the White Paper is to be published without reference to the author then there is no restriction to the changes that may be introduced by Mayflex.

UK Head Office

Telephone +44 (0) 121 326 7557 Fax +44 (0) 121 327 1537 Email sales@mayflex.com
Excel House, Junction Six Industrial Park, Electric Avenue, Birmingham B6 7JJ, United Kingdom.

Middle East Office

Telephone +971 4 7017987 Fax +971 4 7017989 Email mesales@mayflex.com
Mayflex Middle East, PO Box 293695, Office 830, Building 6WB, Dubai Airport Free Zone, Dubai UAE